

2MBIP-4MIR30V-E

4MP VF Vandal-resistant Network IR Bullet Camera



Features

Optics

Day/night functionality

Smart IR , up to 30 m (98 ft) IR distance

IR anti-reflection window to increase the infrared transmittance

2D/3D DNR (Digital Noise Reduction)

Compression

- Ultra 265, H.265, H.264, MJPEG
- Triple Streams

Network

- ONVIF Conformance

Structure

- Wide temperature range: -30°C to 60°C (-22°F to 140°F)
- Wide voltage range of $\pm 25\%$
- IP67
- IK10 vandal resistant
- 3-Axis

CAMERA					
Sensor		1/2.7", 2.0 megapixel, progressive scan, CMOS			
Lens		2.8~12 mm, manual zoom lens			
DORI Distance	Lens	Detect (m)	Observe (m)	Recognize (m)	Identify (m)
	2.8mm	63	25.2	12.6	6.3
	12mm	270	108	54	27
Angle of View (H)		91.0°~27°			
Angle of View (V)		54.4°~13.7°			
Angle of View (O)		118.3°~33.2°			
Adjustment Angle		Pan: 0°~360°, Tilt: 0°~90°, Rotate: 0°~360°			
Shutter		Auto/Manual, 1~1/100000 s			
Minimum Illumination		Colour: 0.02 Lux (F1.6, AGC ON) 0 Lux with IR on			
Digital noise reduction		2D/3D DNR			
Day/Night		IR-cut filter with auto switch (ICR)			
S/N		> 52dB			
IR Range		Up to 30m (98 ft) IR range			
WDR		DWDR			
VIDEO					
Video Compression		Ultra 265,H.265, H.264, MJPEG			
H.264 code profile		Baseline profile, Main Profile, High Profile			
Frame Rate		Main Stream:4MP (2048*1520): Max. 20fps; Sub Stream: 720P (1280*720): Max. 30 fps; Third Stream: D1 (704*576): Max. 30fps			
HLC		Supported			
BLC		Supported			
OSD		Up to 4 OSDs			
Privacy Mask		Up to 8 areas			
ROI		Up to 2 areas			
Motion Detection		Up to 4 areas			
NETWORK					
Protocols		IPv4,IGMP,ICMP,ARP,TCP,UDP,DHCP, RTP,RTSP,RTCP,DNS,DDNS,NTP,FTP,UPnP,HTTP,HTTPS,SMTP, SSL			
Compatible Integration		ONVIF(Profile S, Profile G), API			
INTERFACE					
Network		1 RJ45 100M Base-TX Ethernet			
Edge Storage		MicroSD, up to 128GB			
GENERAL					
Power		12 V DC $\pm 25\%$, PoE (IEEE802.3 af)			
Power Consumption		Power consumption: Max 6.5W			
Dimensions (L x W x H)		253.4x86x71.7mm(9.98"x3.4"x2.8")			
Weight		1kg(2.2lb)			
Working Environment		-30°C ~ +60°C (-22°F ~ 140°F), Humidity :10%~90% RH (non-condensing)			
Ingress Protection		IP67			

Dimensions

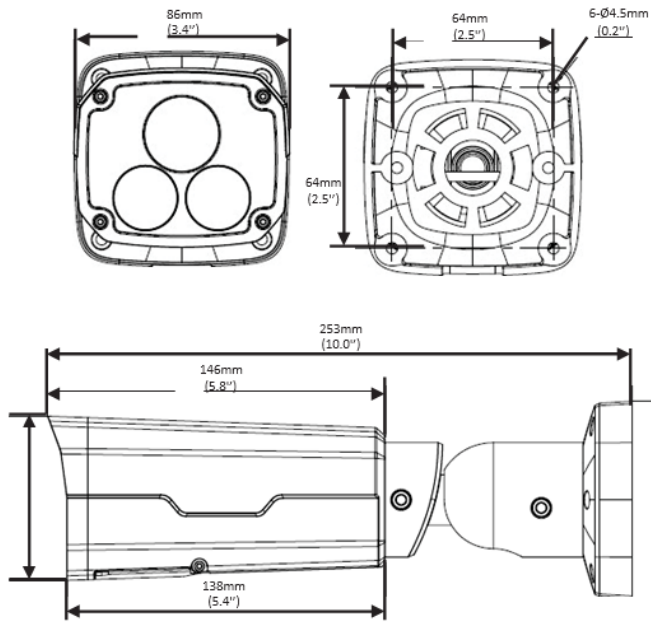

*Product specifications and availability are subject to change without notice.