

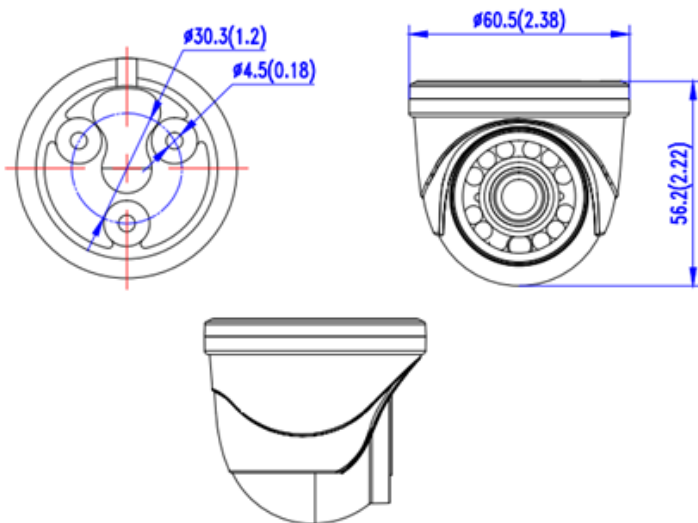

Features

- 1/2.9" 2.1 Mega-pixel Sony CMOS
- Supports four video signal output (AHD/TVI/CVI/CVBS), default video output is AHD
- Support Dip switch for signal changes
- 12PCs IR LEDs, IR Range: 10m (32.8ft) (indoor)
- 3.6mm IR Lens
- Defog, DWDR, 3DNR, DSS, UTC

Dimensions



SPECIFICATIONS	
IP Rating	IP65
Filter	Removable IR Cut Filter
Image Sensor	1/2.9"Sony 2.1Mega-pixel Sony CMOS
Pixels	1920(H)*1080(V)
Horizontal Resolution	1080P
Minimum Lux	0 Lux (12 Pieces IR LED ON)
Vertical Frequency	NTSC: 60Hz PAL:50Hz
Scanning System	Progressive
S/N Ratio	≥ 52 dB
Electronic Shutter	NTSC:1/60-1/100,000S PAL:1/50-1/100,000S
Lens	3.6mm IR Lens
White Balance	ATW
OSD	YES
Back Light Compensation	AUTO
AUTO Gain Control	ON
Defog	OFF/ON
DNR	OFF/ON
WDR	OFF/ON
Day & Night	AUTO/Color/BW/Ext
Available IR Distance	10M (32.8ft)
Gamma	0.45
Video Output	HD-AHD (TVI / CVI / CVBS)
Power Supply	DC12V \pm 10%
Current consumption	280mA (MAX)
Dimension	$\phi 60.5 \times 56.2$ (mm) ($\phi 2.38" \times 2.22"$)
Weight	180g (6.35oz)
Storage Temperature	-30°C+60°C
Operating Temperature	-30°C+40°C