

2MEP04-T2M33X

2MP HD Analog AHD PTZ Dome Camera 33x with
 Stainless Steel Explosion proof Housing – 304 Stainless Steel



Features

- 4-in-1 video output (TVI/AHD/CVI/CVB)
- 4.6 - 152mm Motorized Lens
- 33x optical zoom
- 304 Stainless steel construction (Also available in 316L)
- Integrated cable
- IP68 ingress protection rating

CERTIFICATES	
Ex-Proof Mark	Exd IIC T6 Gb/Ext DA21 IP68 T80°C
Certificate No	CNEx15.3070X
Standards	Q/320412 ZAF026-2015
MECHANICAL	
Housing	Stainless steel 304
IP	IP68
Cable Threaded Hole	1pcs G3/4 or NPT3/4
Wiper	No
ELECTRICAL	
Voltage	AC 24V±20%
Power	8-20W
AMBIENT	
Ambient Temperature	-25°C to 60°C
Air Pressure	80Kpa to 106Kpa
Relative Humidity	≤95% (no condensation)
PAN & TILT	
Horizontal	360°
Speed	Horizontal 0.1-300°/s, Vertical 0.1-250°/s
Vertical	-90° to 0°
Cruise Scan	Supported
Keep Watch	Supported
Preset	64/128/255/300
Resume Function	Supported
Auto Cruise	Supported
Auto Scan	Supported
CAMERA	
Image Sensor	1/2.8" CMOS (sensor: sony 291)
Effective Pixel	1920 x 1080
Min. Illumination	0.01LUX
Shutter Time	1/6 sec~ 1/10,000 sec
Day & Night	Auto ICR
S/N Ratio	More than 52dB
Support	White balance, auto gain control
Video Type	PAL/ NTSC
LENS	
Focal Length	4.6-152mm, 33X optical
Aperture Range	F1.5-F3.0
Angle of View	55.93 to 3.52 degree (Wide-Tele)
Min. Working Distance	100mm-1000mm (Wide-Tele)
COMMUNICATION	
Video Output	Switchable TVI/AHD/CVI/CVB video output, (NTSC or PAL composite, BNC) , 1.0±0.2Vp-p,
AHD video	Female BNC
Protocol	PELCO-D, PELCO-P, SAE
Communication way	Support RS485/ Coaxial
Baud rate	2400/4800/9600/19200bps
Address	0-255

GENERAL

Cable	Integrated cable
Dimensions	213 x 213 x 570 (mm)/8.4" x 8.4" x 22.4" (in.)
Weight	15kg/33.1 lbs
Mounted	Wall, pole

Features

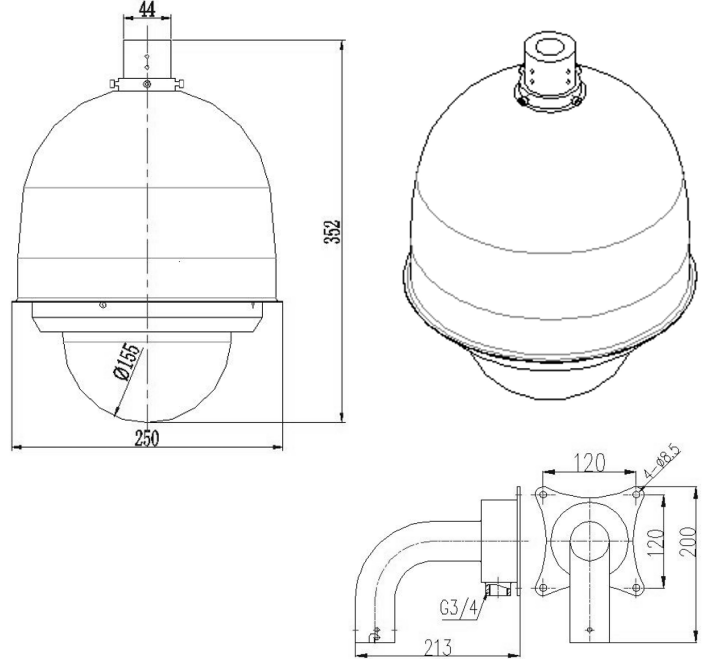

ATEX Markings Breakdown

