

# 2MEPIR04-T2M33X

2MP Analog Explosion proof PTZ Camera 33x Zoom – 304 Stainless Steel



## Features

- 304 Stainless steel
- Certificate Mark: ExdII C T6 GB/DIP A20 TA, T6
- Protection enclosure: IP68
- 100m light distance
- Integrated cable
- Integrated with pan tilt station
- Infrared lights
- Wiper included
- Optical zoom 33x, digital zoom 16x

CERTIFICATES	
<b>Certification</b>	ExdII C T6 GB/DIP A20 TA, T6
MECHANICAL	
<b>Housing</b>	Stainless Steel 304 (also available in 316L)
<b>Wiper</b>	Yes
<b>IP</b>	IP68
<b>Cable Thread Hole</b>	1pcs G3/4 or NPT3/4
ELECTRICAL	
<b>Voltage</b>	AC85V~AC265V or DC24V or AC24V
<b>Power</b>	50W/70W (with thermostat)
AMBIENT	
<b>Ambient Temperature</b>	-25°C to 60°C [-13°F to 140°F]
<b>Air Pressure</b>	80Kpa to 106Kpa
<b>Relative Humidity</b>	<95% (no condensation)
LIGHTS	
<b>Light Distance</b>	100m
<b>Light Control</b>	Supports
COMMUNICATIONS	
<b>Communication</b>	Supports analog video output
<b>485 Communication</b>	Supports Pelco-D, Pelco-P
<b>Communication Rate</b>	2400 to 19200bps
PAN & TILT	
<b>Horizontal</b>	360°
<b>Horizontal Speed</b>	0.1-45°/s
<b>Vertical</b>	90 to +90°
<b>Cruise Scan</b>	Supported
<b>Keep Watch</b>	Support
<b>Preset</b>	64/128/255
<b>Resume Function</b>	Supported
<b>Auto Cruise</b>	Supported
<b>Auto Scan</b>	Supported
CAMERA	
<b>Image Sensor</b>	1/3" interline-transfer CCD
<b>Effective Pixel</b>	PAL 976 x 582 / NTSC 976 x 494
<b>Min. Illumination</b>	Color 0.04 Lux / B/W: 0.004Lux
<b>Shutter Time</b>	1/50 (1/60) sec ~ 1/10,000 sec
<b>Day &amp; Night</b>	Auto ICR
<b>Horizontal Resolution</b>	700TVL (color), 720TVL (B&W)
<b>S/N Ratio</b>	> 50dB (AGC off)
LENS	
<b>Focal Length</b>	4 - 92mm, 33x optical
<b>Aperture Range</b>	F1.5 - F3.6
<b>Angle of View</b>	49 - 2.2 degree (Wide-Tele)
<b>Min. Working Distance</b>	10mm - 1500mm (Wide-Tele)
<b>Zoom Speed</b>	Speed Approx. 3s (Optical, Wide-Tele)

### CONTROL

<b>Camera Address</b>	on/off (0-254)
<b>Focus Mode</b>	Auto/Manual/One touch
<b>Gain</b>	off/ lower/ higher
<b>Slow Shutter</b>	X256 MAX
<b>White Balance</b>	Auto white balance 1/auto white balance 2/Manual/auto
<b>Private</b>	Off/ Mode 1/ Mode 2
<b>Video</b>	3D DNR, mirror, brightness, Contrast, Sharpness adjustable
<b>Digital Zoom</b>	X16
<b>Zoom Display</b>	on/off
<b>ZCF Control Mode</b>	Mode 1, mode 2
<b>RS485</b>	Protocol, baud rate, address
<b>Preset</b>	Preset

### GENERAL

<b>Cable</b>	Integrated Cable
<b>Dimensions (LxWxH)</b>	319 x 240 x 420 (mm) [ 12.6" x 9.4" x 16.5" (in)]
<b>Weight</b>	16kg [35.3 lbs]
<b>Mount</b>	Wall

### Dimensions

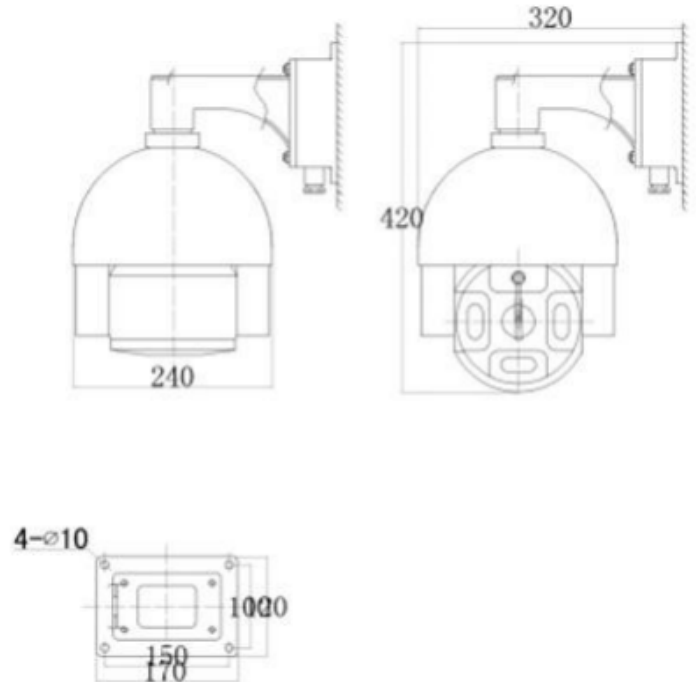

### ATEX Markings Breakdown

#### MARKING ACCORDING ATEX DIRECTIVE 94/9/EC AND IECEx CERTIFICATION SCHEME

