

2MEXH-2666

Explosion-Proof IR Bullet Camera Housing

Instruction Manual



2MEXH-2666 Explosion-Proof IR Bullet Camera Housing

Installation

- Install all cables or fiber optic lines at the outlet in accordance with this manual.
- Before powering on the equipment, ensure the power supply matches the specifications on the equipment nameplate.
- Always disconnect power before performing any maintenance or servicing.
- Operate the equipment only within the environmental conditions specified in this manual.
- During maintenance, take care to protect the explosion-proof surfaces.
- Prevent metal shavings or foreign materials from entering the device.
- Do not disassemble or modify the equipment without authorization.

Maintenance

- Before performing maintenance, ensure the power supply is disconnected and the equipment is removed. Reinstall the equipment only after confirming normal operation through electrical testing.
- This company manufactures various products and components that may impact the environment, such as circuit boards, electronic components, plastics, and lubricants. During maintenance or disposal, properly collect and manage all waste materials. Do not discard them carelessly; instead, hand them over to the appropriate environmental protection authorities to prevent environmental harm.

Overview

- It is designed for easy operation, flexible configuration, and enhanced usability while maintaining strict explosion-proof safety standards.
- It complies with EN IEC 60079-0:2018, EN 60079-1:2014, and EN 60079-31:2014 standards. It is an intelligent, dual-certified explosion-proof camera for both gas and dust hazardous environments.
- Explosion-proof rating: II 2G Ex db IIC T6 Gb / II 2D Ex tb IIIC (85°C) Db.
- Suitable for use in hazardous locations with flammable gases (IIA, IIB, IIC; T1–T6) in Zone 1 and Zone 2, as well as environments with combustible dust (Zones 20, 21, and 22).
- Designed for real-time monitoring, anti-theft security, and long-distance surveillance applications.

2. Technical Requirements

2.1 General Compliance

- The camera must comply with applicable standards and be manufactured according to approved drawings, procedures, and technical documentation.

2.2 Environmental Requirements

The camera is designed to operate reliably under the following conditions:

- Altitude: Up to 1,800 meters above sea level
- Temperature range: -30°C to +70°C
- Relative humidity: ≤95% at +25°C
- Suitable for hazardous environments containing flammable gases (Class II, IIB, IIC where applicable; T1–T6) in Zones 1 and 2
- Suitable for areas with combustible dust and air mixtures (Zones 20, 21, and 22)
- Free from corrosive substances that could damage insulation materials
- No significant vibration or mechanical shock
- Suitable for locations exposed to splashing or rainwater

2.3 Transport Durability

- The equipment is designed to withstand typical stresses encountered during transportation under worst-case shipping conditions.
 - Environmental conditions
 - High temperature
 - Low temperature
 - Humidity
 - Vibration
 - Hit

2.4 Product Certification

Ex Marking: II 2G Ex db IIC T6 Gb II 2D Ex tb IIIC (85°C) Db

Ex Certification No.: IEP 14 ATEX 0251

2.5 Technical Parameter

- Material: 304/316L stainless steel
- Ingress Protection: IP68
- Interface Spec: M25
- External dimensions (LxWxH): 385 × 137 × 145 mm
 - With IR: 385 × 137 × 232 mm
- Inside dimension (LxWxH): 260 × 100 × 100 mm
- Weight: ≤8kg
- Rated Temperature: (-30°C, +70°C)
- Atmospheric Pressure: 80-106KPa
- Relative Humidity: ≤95%RH(+25°C)

3. Product Dimension

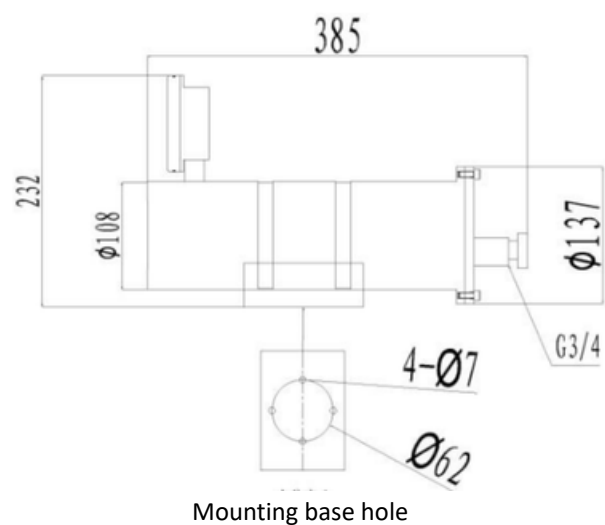
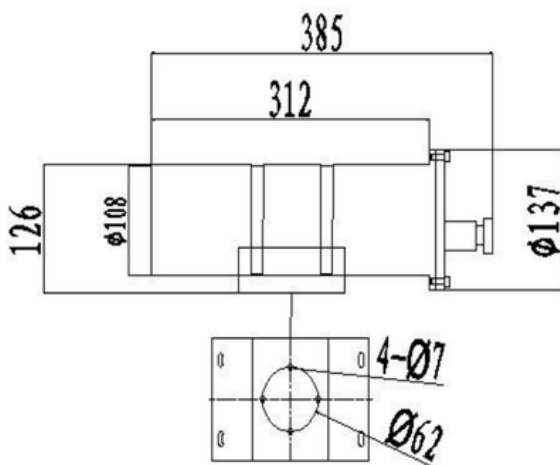

4. Wiring installation, use, and precautions

Pre-Use Inspection

Do not operate the equipment unless all of the following conditions are met:

- The camera has a valid explosion-proof marking and certificate number.
- The camera is suitable for the intended hazardous environment (gas and/or dust).
- Grounding screws and markings are present both inside and outside the unit.
- All components are intact, with no visible damage or missing parts.

- Installation, wiring, commissioning, repair, and maintenance must be performed strictly in accordance with the user manual.
- This ensures high reliability and accurate performance of the camera.
- During installation and maintenance (internal and external), verify that all wiring connections are secure and in good condition, and that all components are properly installed.

Explosion-Proof Integrity

- To maintain explosion-proof performance, do not loosen or remove any fasteners on the camera.
- Modification or replacement of camera components is strictly prohibited.

Camera and Lens Installation

- Carefully review the product manual before installation to ensure compatibility between the camera sensor (CCD) and the lens.
- A 1/3" CCD camera can use either a 1/3" or a 1/2" lens.
- A 1/2" CCD camera must use only a 1/2" lens.
- Using an incompatible lens may result in dark edges (vignetting) in the image.

After installation:

- Adjust the camera's back focal length and check image clarity using a test monitor.
- Mount the camera and lens assembly onto the housing tray.
- Fine-tune the front and rear positioning to ensure a clear image with no dark corners

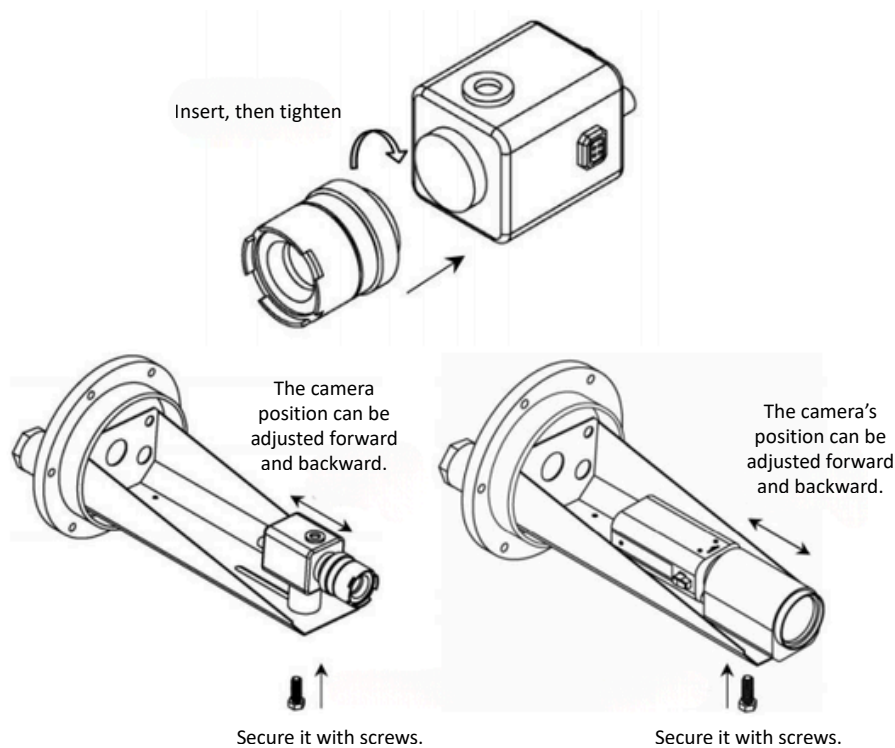

5. Wiring

5.1 Using Explosion-Proof Flexible Conduit

- When routing cables, install components in the correct sequence. Feed the cable through the explosion-proof flexible conduit, then pass it through the compression nut, metal washer, rubber sealing ring, and inlet fitting body.
- Tighten the compression nut to press the rubber sealing ring into the cable until it grips the cable firmly. The cable diameter must match the sealing ring diameter (tolerance within 1 mm). If necessary, reshape the cable to ensure a proper seal.
- After securing the seal, tighten the explosion-proof flexible conduit to the connection nut. All power cables must also be routed through explosion-proof conduit.
- At the cable outlet, install components in the following order: rubber sealing ring, blanking plug (blind pad), metal washer, and finally tighten the gland nut securely.

Installation Notes

- Pre-install all required components onto the explosion-proof flexible conduit before assembly. After removing the compression nut, retain the standard washer and rubber sealing ring (or use spare parts provided in the packaging).
- First, tighten the threaded connection, then secure the explosion-proof flexible conduit.
 - As illustrated in Figure 1, ensure all components are properly placed on the conduit in advance. After removing the compression nut, keep the standard washer and rubber sealing ring (or use the supplied spare parts).

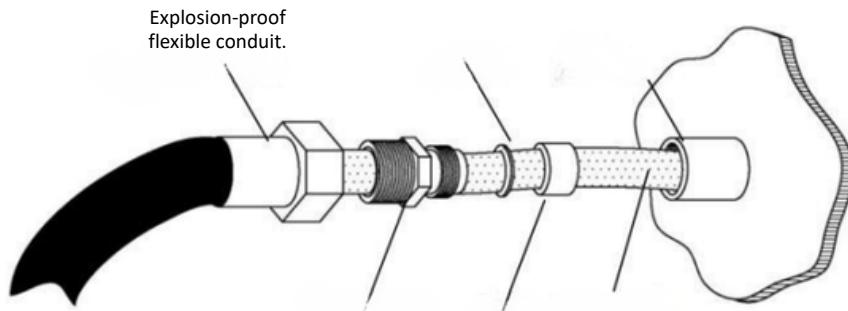

Figure 1

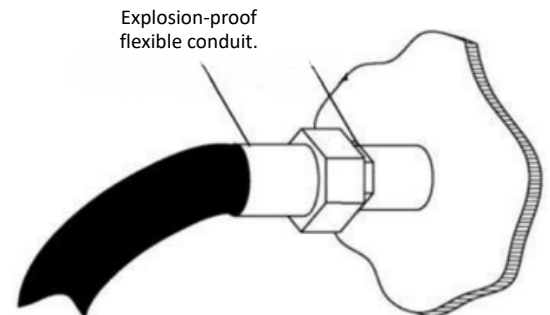

Figure 2

As shown in Figure 2, first tighten the threaded joint, then secure the explosion-proof flexible conduit.

5.2 Use of Armored Cable

As shown in Figure 3, strip an appropriate length of the cable's outer sheath according to actual requirements to expose the metal armor (steel tape). Retain a suitable length of the steel tape and remove any excess material.

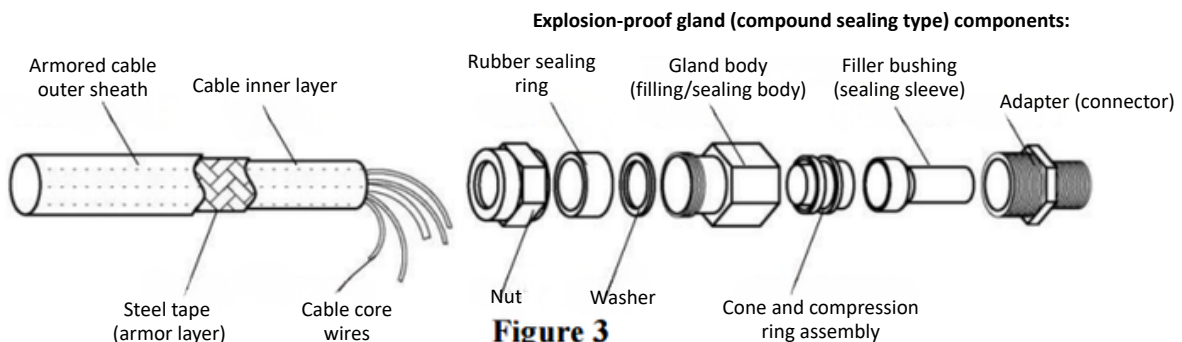

Figure 3

As shown in Figure 4, install the explosion-proof gland onto the armored cable. For details on its use, refer to the document “Installation and Use of Explosion-Proof Gland.”

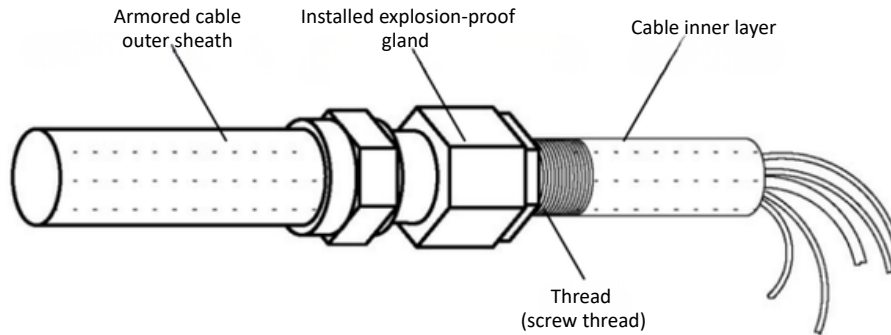

Figure 4

Armored Cable Connection

- Armored cables with explosion-proof glands can be directly and securely connected to various types of explosion-proof equipment.

5.3 Explosion-Proof Camera Housing Installation

- Due to the high explosion-proof rating, the housing’s explosion-proof surfaces are precision-fitted. Extra care must be taken during installation to avoid damage.
- The back panel and rear housing surfaces are explosion-proof interfaces and must not be scratched, dented, or impacted.
- An insulating gasket is installed between the drawer board and the back panel. If disassembled, ensure the gasket maintains proper insulation performance.
- After installation, the insulation resistance must be tested and should be no less than 100 MΩ.
- The center of the back panel includes an external grounding bolt, which must be securely connected to a reliable ground during installation.

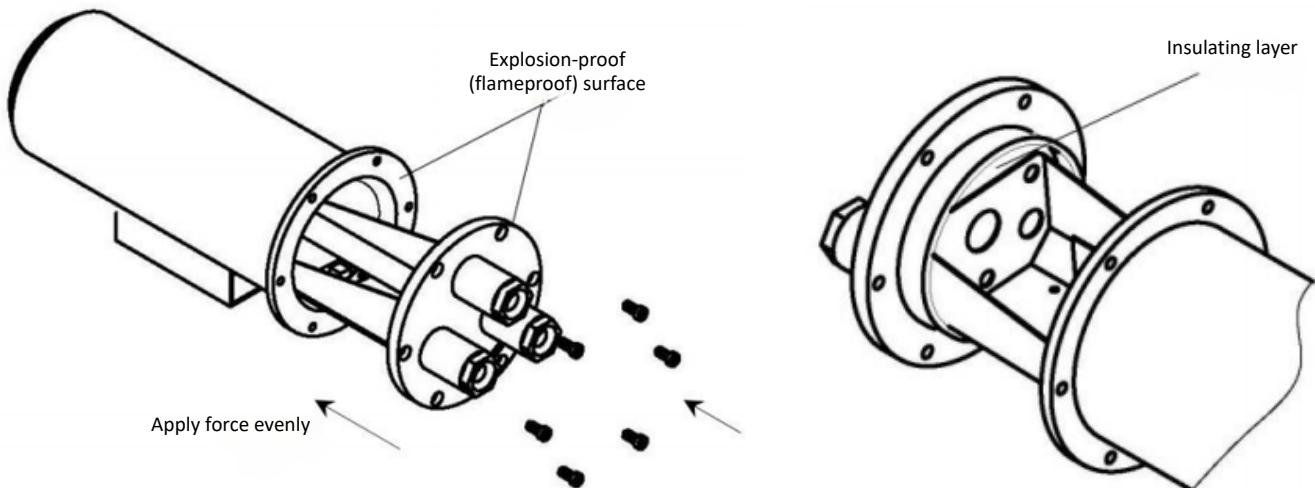

6. Maintenance knowledge

- This camera is designed for specialized environments. Always disconnect the power supply before opening the rear cover.
- Avoid opening the rear cover in high-humidity conditions whenever possible. Due to the housing's strong sealing performance, internal moisture may be difficult to dissipate over time, which can result in blurred images.
- If exposed to harsh environments for extended periods, the protective lens may accumulate dirt. Clean it regularly to maintain clear transparency.
- Inspect the elastic sealing ring at the cable entry point on a regular basis. If aging causes loss of elasticity, it must be replaced with a spare part of the same size and hardness specification. Do not substitute with other materials.
- Regularly check all bolts to ensure they are secure and free from damage or looseness.
- Periodically remove any dirt, dust, or moisture from the internal housing of the camera.
- Perform routine inspections to confirm the camera is in good condition and operating normally.

Troubleshooting tips:

- No image
 - power disconnection => check the power supply, the wire, and the connection
 - Video line disconnected => Check the wire and connection
 - Camera damage => Change camera
 - Lens breakdown => Change lenses

7. Transportation and storage

- Protect the camera from exposure to rain and snow during transportation and storage.
- Store the camera in a well-ventilated warehouse free from water leakage or liquid exposure. The relative humidity should not exceed 90%, and the ambient temperature should be between -25°C and +40°C.
- The storage environment must be free of corrosive substances or materials that could damage the cable insulation or metal components.