



Features

- High quality image with 5 MP, 1/2.8" CMOS sensor
- Ultra 265, H.265, H.264, MJPEG
- Smart intrusion prevention, supports false alarm filtering, including cross line, intrusion, enter area, leave area detection
- LightHunter technology ensures ultra-high image quality in low illumination environment
- Up to 120 dB WDR (wide dynamic range)
- Built-in mic and speaker
- Smart IR, up to 50 m (164.0 ft) IR distance and 15 m (49.2 ft) warm light distance
- MicroSD, up to 512 GB
- IP66 protection
- DC 12 V, PoE (IEEE 802.3at) power supply

Specifications

CAMERA		
Max Resolution		5MP
Sensor		1/2.7" CMOS
Min. Illumination		Color: 0.005 Lux (F1.2, AGC ON), 0 Lux with IR
Day/Night		IR-cut filter with auto switch (ICR)
Shutter		Auto/Manual, 1 s to 1/100000 s
WDR		120 dB
S/N		>56 dB
LENS		
Focal Length		2.7–13.5 mm
Optical Zoom		5x
Iris		F1.2
Field of View	H	106.9°–30.6°
	V	56°–17.7°
	D	131.5°–36.1°
DORI		
DORI Distance	Detect	70.9–247.5 m (232.5–812 ft)
	Observe	28.4–99 m (93.2–324.8 ft)
	Recognize	14.2–49.5 m (46.5–162.4 ft)
	Identify	7.1–24.8 m (23.3–81.4 ft)
ILLUMINATOR		
Light On/Off Control		Auto/Manual
Wavelength		850 nm
Illumination Distance	IR	50 m (164 ft)
	Warm Light	15 m (49.2 ft)
VIDEO		
Video Compression		Ultra 265, H.265, H.264, MJPEG
Frame Rate	Main Stream	5MP (2880 × 1620), max. 30 fps
	Sub Stream	720P (1280 × 720), max. 30 fps
	Third Stream	D1 (720 × 576), max. 30 fps
Video Bit Rate		128 Kbps to 16 Mbps
Video Stream		Triple streams



Specifications

U-Code	Support
ROI	Support
Privacy Mask	Up to 4 areas
OSD	Up to 8 OSDs
IMAGE	
White Balance	Auto, Outdoor, Fine tune, Sodium lamp, Locked, Auto2
Digital Noise Reduction	2D/3D DNR
Flip	Normal, Flip vertical, Flip horizontal, 180°
HLC	Support
BLC	Support
Smart IR	Support
Defog	Digital defog
AUDIO	
Audio Compression	G.711U, G.711A
Audio Bitrate	128 Kbps
Two-Way Audio	Support
Suppression	Support
Sampling Rate	16 KHz
INTELLIGENT	
Auto Tracking	Support, target filtering: human only
Smart Intrusion Prevention	Cross line detection, intrusion detection, enter area detection, leave area detection (false alarm filtering and classification of human, non-motor vehicle, and vehicle)
People Counting	People flow counting, crowd density detection
Exception Detection	Object removed, Object Left Behind, Scene change, Defocus detection
EVENTS	
Basic Detection	Motion detection, Tampering alarm, Audio detection, Object removed, Object Left Behind, Scene change, Defocus detection
General Function	Watermark, IP address filtering, Access policy, ARP protection, RTSP authentication, User authentication

STORAGE		
Edge Storage	MicroSD, up to 512 GB	
Network Storage	ANR, NAS (NFS)	
NETWORK		
Protocols	TLS1.3, SSH, IGMP, RTP, RTCP, SMTP, IPv4, IPv6, ICMP, ARP, TCP, UDP, DHCP, PPPoE, RTSP, RTMP, DNS, DDNS, NTP, FTP, UPnP, HTTP, HTTPS, 802.1x, SNMP, QoS, SSL/TLS	
Compatible Integration	ONVIF (Profile S, Profile G, Profile T, Profile M), API, SDK	
Security	Password Protection, Strong Password, HTTPS Encryption, Export Operation Logs, Basic and Digest Authentication for RTSP, Digest Authentication for HTTP, TLS 1.2, WSSE and Digest Authentication for ONVIF	
Client	EZStation, UNV-Link, UNV-Link Pro	
Web Browser	Plug-in required live view: IE 10 and above, Chrome 45 and above, Firefox 52 and above, Edge 79 and above	
PTZ		
Number of Presets	1024	
Preset Patrol	16 patrols, up to 64 presets for each patrol	
Patrol Stay Time	120–1800 s	
Home Position	Support	
Pan	Range	0°–345°
	Speed	1°/s–50°/s
Tilt	Range	-10°–100°
	Speed	1°/s–40°/s
INTERFACE		
Audio I/O	Input	1: impedance 1 kΩ, amplitude 2.5 V [p-p]
	Output	1: impedance 600 Ω, amplitude 2.5 V [p-p]
Alarm I/O	1/1	
Built-In Mic	Support	
Built-In Speaker	Support	
Network	1 × RJ45 10 M/100 M Base-TX Ethernet	



Specifications

CERTIFICATION	
EMC	CE-EMC (EN 55032: 2015+A11: 2020+A1: 2020, EN 50130-4: 2011+A1: 2014, EN 61000-3-3: 2013+A1: 2019+A2: 2021, EN IEC 61000-3-2: 2019+A1: 2021)
Safety	CE LVD (EN 62368-1: 2020+A11: 2020) UL (UL 62368-1, 2nd Ed., Issue Date: 2014-12-01)
Environment	CE-ROHS (2011/65/EU;(EU)2015/863)
Protection	IP66 (IEC 60529:1989+AMD1:1999+AMD2:2013)
GENERAL	
Power	DC 12 V (±25%), PoE (IEEE 802.3at)
Power Consumption	18 W
Power Interface	Ø5.5 mm coaxial power plug
Dimensions (L × W × H)	185 mm × 133 mm × 286 mm (7.3" × 5.2" × 11.3")
Weight	1.32 kg (2.91 lb)
Working Environment	Temperature -30°C to 60°C (-22°F to 140°F)
	Humidity ≤95% RH (non-condensing)
Storage Environment	Temperature -40°C to 70°C (-40°F to 158°F)
	Humidity ≤95% RH (non-condensing)
Surge Protection	2 KV
Reset Button	Support
Heater	Support
Web Client Language	22 Languages: Traditional Chinese, English, Simplified Chinese, Polish, German, Russian, French, Korean, Dutch, Czech, Portuguese (Europe), Portuguese (Brazil), Japanese, Thai, Turkish, Spanish (Latin America), Spanish (Europe), Hungarian, Italian, Vietnamese, Arabic, Slovak
CONFIGURABLE	
P/N	Support

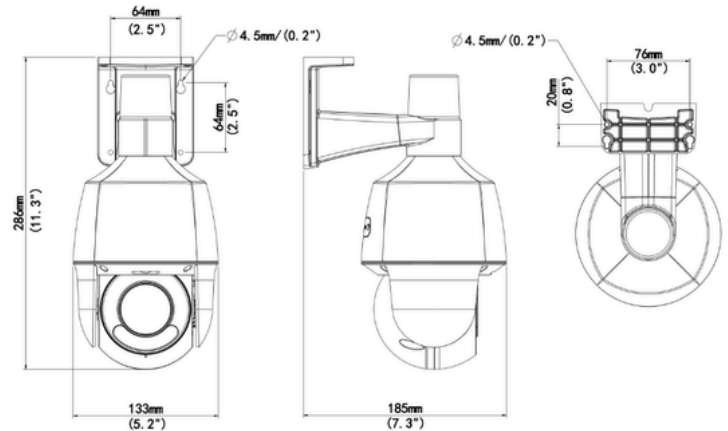
Dimensions



Accessories

Bullet Junction Box (wiring from behind)	Alarm Ball Machine Hoisting Bracket	NPT 3/4" Waterproof Cable Gland
		
Pole Mounting Bracket for Bullet Junction Box	Bullet Pole Mounting Bracket	
	